

Product Features

- Compliant with IEEE Std 802.3cd, 50G Ethernet LR
- Compliant with QSFP28 MSA per SFF-8665 & SFF-8636
- Duplex LC receptacles
- DFB Laser, PIN photo detector
- Up to 53.125G data links
- Single +3.3V power supply
- Class 1 laser safety certified
- Operating temperature:
 - (Commercial) 0°C to +70°C
- Up to 10km over G.652 SMF
- RoHS 6/6 Compliant



Applications

- 50GBASE-LR at 53.125Gbps

Descriptions

LX8802CDR QSFP28 transceiver modules are designed for 50Gigabit Ethernet over single mode fiber. They are compliant with the QSFP28 MSA, IEEE 802.3cd 50GBASE-LR. The transmission distance is up to 10km over G.652 SMF. Digital diagnostics functions are available via the I2C interface, as specified by the QSFP28 MSA.

The modules are compliant with RoHS.

Ordering Information

Table 1. Ordering Information

Part Number	Transmitter	Average Power	Receiver	OMA Sensitivity	Reach	Temp	DDM	RoHS
LX8802CDR	DFB	-4.5 ~ 4.2dBm	PIN	< -8.4dBm	10km	0 ~ 70 °C	Available	Compliant

Pin Description

Table 2. Pin Description

Pin	Name	Function/Description	Notes
1	GND	Ground	1
2	Tx2n	Transmitter Inverted Data Input, CML-I	
3	Tx2p	Transmitter Non-Inverted Data output, CML-I	
4	GND	Ground	1
5	Tx4n	NC	
6	Tx4p	NC	
7	GND	Ground	1
8	ModSelL	Module Select, LVTTTL-I	
9	ResetL	Module Reset, LVTTTL-I	
10	VccRx	3.3V Power Supply Receiver	
11	SCL	2-Wire serial Interface Clock, LVCMOS-I/O	2
12	SDA	2-Wire serial Interface Data, LVCMOS-I/O	2
13	GND	Ground	1
14	Rx3p	NC	
15	Rx3n	NC	
16	GND	Ground	1
17	Rx1p	Receiver Non-Inverted Data Output, CML-O	
18	Rx1n	Receiver Inverted Data Output, CML-O	
19	GND	Ground	1
20	GND	Ground	1
21	Rx2n	Receiver Inverted Data Output, CML-O	
22	Rx2p	Receiver Non-Inverted Data Output, CML-O	
23	GND	Ground	1
24	Rx4n	NC	1
25	Rx4p	NC	
26	GND	Ground	1
27	ModPrsL	Module Present, LVTTTL-O	
28	IntL	Interrupt/RxLOS, LVTTTL-O	
29	VccTx	3.3V Power Supply Transmitter	
30	Vcc1	3.3V Power Supply	
31	LPMMode	Low Power Mode/TxDis, LVTTTL-I	
32	GND	Ground	1
33	Tx3p	NC	
34	Tx3n	NC	
35	GND	Ground	1
36	Tx1p	Transmitter Non-Inverted Data Input, CML-I	
37	Tx1n	Transmitter Inverted Data Output, CML-I	
38	GND	Ground	1

Notes:

Absolute Maximum Ratings

Stresses in excess of the absolute maximum ratings can cause permanent damage to the device. These are absolute stress ratings only. Functional operation of the device is not implied at these or any other conditions in excess of those given in the operational sections of the data sheet. Exposure to absolute maximum ratings for extended periods can adversely affect device reliability.

Table 3. Absolute Maximum Ratings

Parameter	Symbol	Minimum	Maximum	Unit
Storage Temperature	T _s	-40	85	°C
Relative Humidity	RH	5	85	%
Supply Voltage	V _{CC}	-0.5	3.6	V

Recommended Operating Conditions

Table 4. Recommended Operating Conditions

Parameter	Symbol	Min	Typ	Max	Unit
Operating Case Temperature	T _c	0	25	70	°C
Supply Voltage	V _{CC}	3.135	3.3	3.465	V
Relative Humidity	RH	5		85	%
Data Rate (Optical)	-	-	53.125	-	Gb/s
Data Rate (Electrical)	-	-	26.5625	-	Gb/s

Transceiver Electrical Characteristics

Table 5. Transceiver Electrical Characteristics

Parameter	Symbol	Minimum	Typical	Maximum	Unit	Notes
Module Steady State Current	I _{CC}	-	-	1010.1	mA	-
Power Dissipation	P _D	-	-	3500	mW	-
Transmitter						
Input Differential Impedance	Z _{IN}	-	100	-	Ω	-
Differential Data Input Swing	V _{IN, P-P}	190	-	900	mV _{P-P}	-
Receiver						
Output Differential Impedance	Z _O	90	100	110	Ω	-
Differential Data Output Swing	V _{OUT, P-P}	228	-	900	mV _{P-P}	-
Low-speed Electrical Interface						
LVTTTL-I: LPMode, ResetL, ModSelL	V _{IL, LVTTTL}	-0.3		0.8	V	
	V _{IH, LVTTTL}	2.0		V _{CC} +0.3	V	
LVTTTL-O: ModPrsL, IntL	V _{OL, LVTTTL}	0.0		0.4	V	

V_{OH, LVTTL} V_{CC-0.5} V_{CC+0.3} V

Transmitter Optical Characteristics

Table 6. Transmitter Optical Characteristics

Parameter	Symbol	Minimum	Typical	Maximum	Unit	Notes
Signaling Rate Range (PAM-4)		26.5625+/-100ppm			GBd	
Center Wavelength Range	λ_c	1304.5		1317.5	nm	-
Side Mode Suppression Ratio	SMSR	30			dB	
Average Launch Power	P _{avg}	-4.5	-	4.2	dBm	1
Optical Modulation Amplitude (OMA)	P _{oma}	-1.5		4	dBm	
Launch Power in OMA minus TDECQ (min)		-2.9			dBm	
Transmitter and Dispersion Eye Closure for PAM4 (max)	TDECQ			3.2	dB	
Average Launch Power of OFF transmitter (max)				-16	dBm	
Extinction Ratio	ER	3.5	-	-	dB	
RIN _{15.6OMA} (max)				-132	dB/Hz	
Optical Return Loss Tolerance	ORLT	-	-	15.6	dB	
Transmitter Reflectance (max)				-26	dB	

Notes:

- Class 1 Laser Safety per FDA/CDRH and EN (IEC) 60825 regulations.

Receiver Optical Characteristics

Table 7. Receiver Optical Characteristics

Parameter	Symbol	Minimum	Typical	Maximum	Unit	Notes
Signaling Rate Range (PAM-4)		26.5625+/-100ppm			GBd	
Center Wavelength Range	λ_c	1304.5		1317.5	nm	-
Damage Threshold		5.2	-		dBm	
Average receive power	R _{pow}	-10.8		4.2	dBm	
Receive power OMA _{outer} (max)	R _{oma}			4	dBm	
Receiver Sensitivity OMA _{outer}	SEN			-8.4	dBm	1
Stressed Receiver Sensitivity OMA _{outer}	SRS			-6.6	dBm	
Overload Receiver Power	ROL	4.2			dBm	1
LOS Assert	LOSA	-30			dBm	
LOS De-assert	LOSD	-	-	-11	dBm	
Receiver Reflectance (max)	RXR			-26	dB	

Notes:

- Measured with a PRBS31 test pattern at 53.125Gbps, BER $\leq 2.4 \times 10^{-4}$.

General Specifications

Tale 8. General Specifications

Parameter	Symbol	Minimum	Typical	Maximum	Unit	Notes
Data Rate (Optical)	BR		53.125		Gb/s	PAM-4
Bit Error Rate	BER			2.4×10^{-4}		
Supported Link Length over G.652 SMF, 53.125Gb/s	L	2		10000	m	

Recommended Host Board Power Supply Filter Network

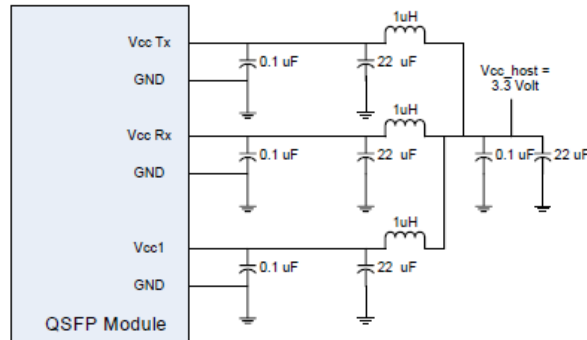

Figure 2. Recommended Host Board Power Supply Filter Network

Recommended Application Interface Block Diagram

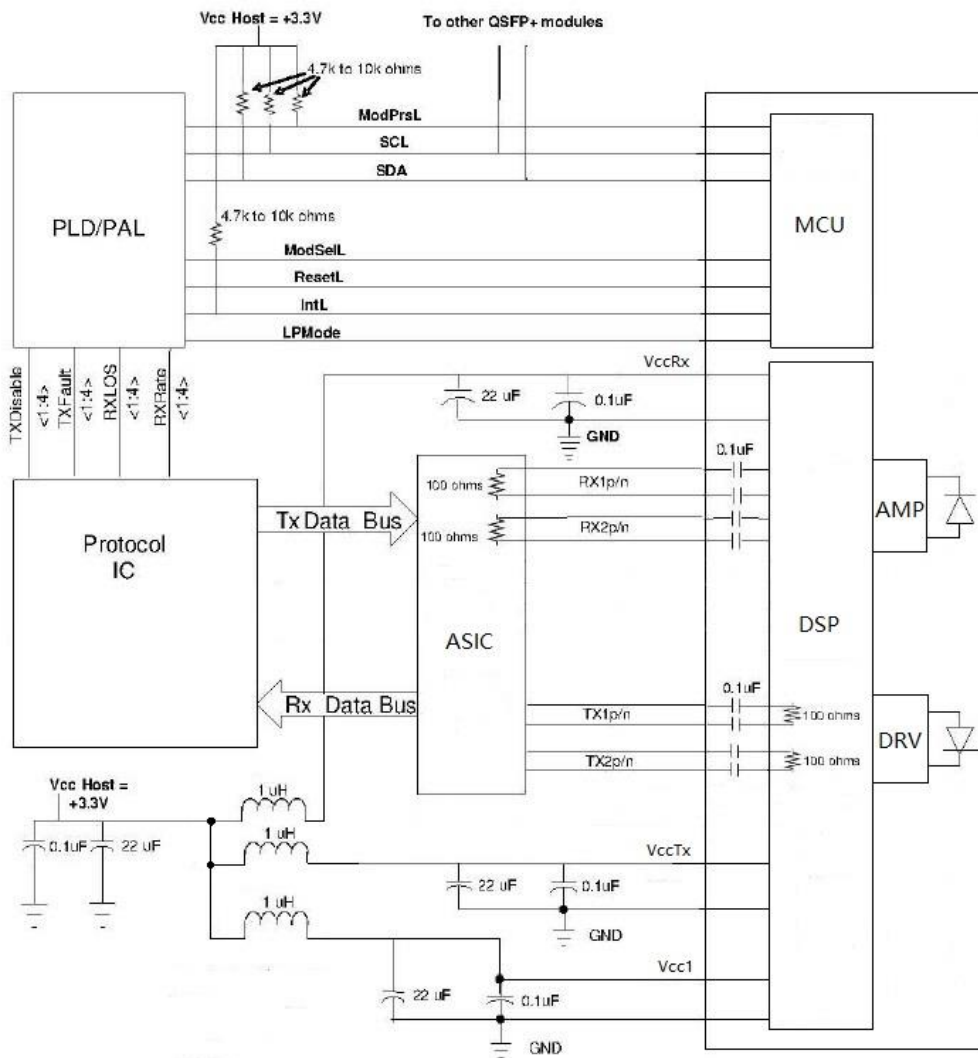

Figure 3. Recommended Application Interface Block Diagram

Mechanical specifications

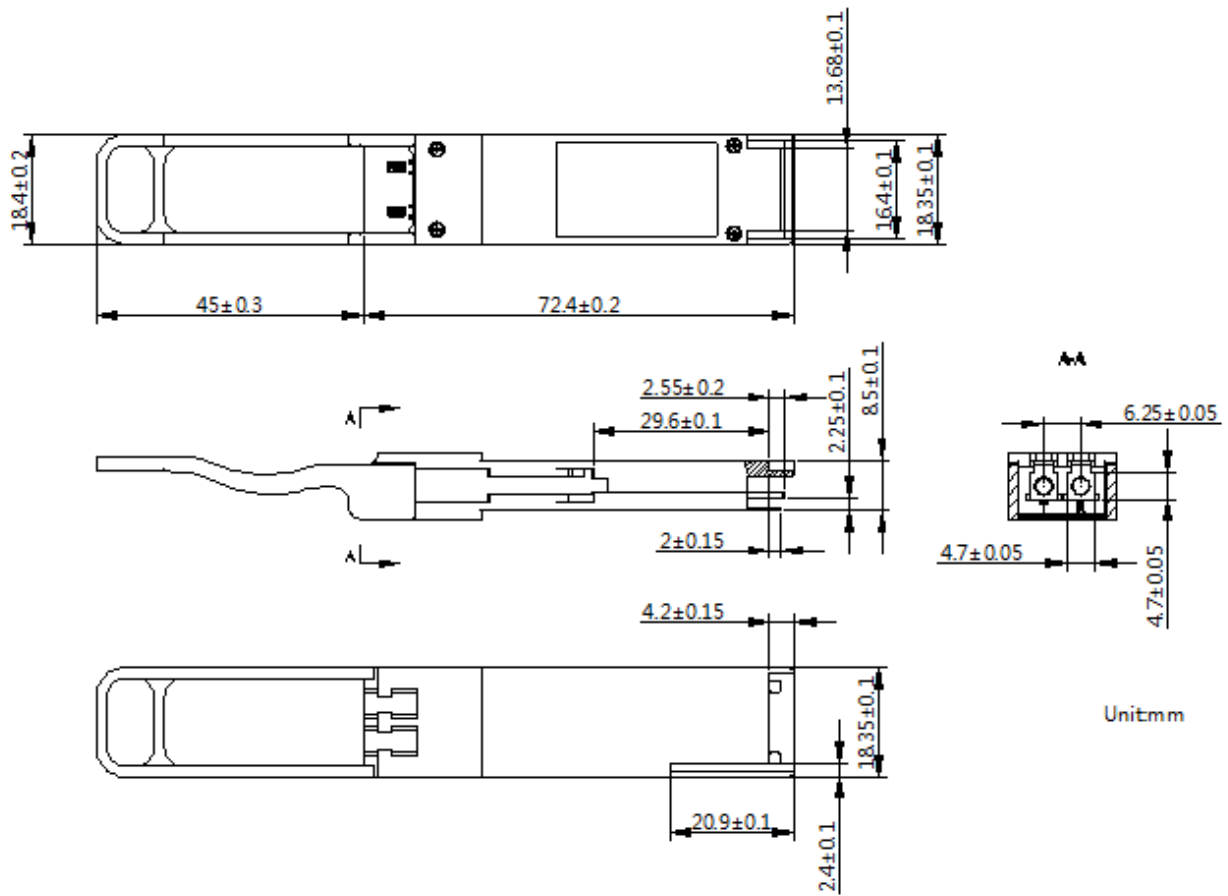

Figure 4. Outline Drawing

Revision History

Date	Rev	Description	Modified By
10/10/2020	V1.0	initial version	Xuguang Chen

For More Information

Linktel Technologies Co., Ltd

info@linkteltech.com

www.linkteltech.com

Linktel USA

1601 McCarthy Blvd #9, Milpitas, CA 95035, USA

Tel: +1 408 807 0482

Email: linktelus@linkteltech.com

jimli@linkteltech.com

Linktel International (Except USA)

E12, No. 52 Liufang Road, East-Lake Hi-tech Development Zone, Wuhan, China

Tel: +86 27 8792 9207

Email: ailsagong@linkteltech.com

Linktel China

E12, No. 52 Liufang Road, East-Lake Hi-tech Development Zone, Wuhan, China

Tel: +86 27 8792 9213

Email: lifan@linkteltech.com