

Product Features

- Compliant to industrial standard SFF-8436 QSFP+ active optical modules
- Compliant to the IEEE802.3ba(40GBASE-SR4)
- Automatic power down while broken cable is detected to improve eye safety
- High speed / high density: support up to 4X10 Gb/s bi-directional operation
- Low power consumption : less than 1.5W
- Reliable VCSEL and PIN photonic devices
- I2C standard management interface
- Excellent high speed signal integrity
- Operating temperature Options
 - (Commercial) 0°C to +70°C
- RoHS6 Compliant



Applications

- 10G/40G Ethernet
- Proprietary high speed, high density data
- High performance computing, server and data storage.

Descriptions

LX497x is a 40Gb/s, hot pluggable active optical cable for Infiniband and Ethernet data transmission. It provides parallel interconnects: 4 transmitting / 4 receiving data lanes and supports distance up to 100 meters.

LX497x is composed of multi-channel optical transceivers in both ends and multimode fiber cable in between. This integrated optical module solution removes the complicated optical fiber interface and brings friendly and intuitive electrical-to-electrical interface to users.

LX497x is designed to meet the requirements of high speed, high density and low power consumption for applications in today's data centers.

Ordering Information

Table 1. Ordering Information

Part Number	Reach	Temp	RoHS
LX4971CDR	1m	0 ~ 70 °C	Compliant
LX4972CDR	2m	0 ~ 70 °C	Compliant
LX4973CDR	3m	0 ~ 70 °C	Compliant
LX4974CDR	5m	0 ~ 70 °C	Compliant
LX4974CDL	7m	0 ~ 70 °C	Compliant
LX4975CDR	10m	0 ~ 70 °C	Compliant

LX4976CDR	20m	0 ~ 70 °C	Compliant
LX4977CDR	30m	0 ~ 70 °C	Compliant
LX4978CDR	50m	0 ~ 70 °C	Compliant
LX4979CDR	100m	0 ~ 70 °C	Compliant

Pin Description

Table 2. Pin Description

Pin	Name	Function/Description	Notes
1	GND	Transmitter Ground (Common with Receiver Ground)	1
2	Tx2-	Transmitter Inverted Data Input	
3	Tx2+	Transmitter Non-Inverted Data output	
4	GND	Transmitter Ground (Common with Receiver Ground)	1
5	Tx4-	Transmitter Inverted Data Input	
6	Tx4+	Transmitter Non-Inverted Data output	
7	GND	Transmitter Ground (Common with Receiver Ground)	1
8	ModSelL	Module Select	2
9	ResetL	Module Reset	2
10	VccRx	3.3V Power Supply Receiver	
11	SCL	2-Wire serial Interface Clock	2
12	SDA	2-Wire serial Interface Data	2
13	GND	Transmitter Ground (Common with Receiver Ground)	1
14	Rx3+	Receiver Non-Inverted Data Output	
15	Rx3-	Receiver Inverted Data Output	
16	GND	Transmitter Ground (Common with Receiver Ground)	1
17	Rx1+	Receiver Non-Inverted Data Output	
18	Rx1-	Receiver Inverted Data Output	
19	GND	Transmitter Ground (Common with Receiver Ground)	1
20	GND	Transmitter Ground (Common with Receiver Ground)	1
21	Rx2-	Receiver Inverted Data Output	
22	Rx2+	Receiver Non-Inverted Data Output	
23	GND	Transmitter Ground (Common with Receiver Ground)	1
24	Rx4-	Receiver Inverted Data Output	1
25	Rx4+	Receiver Non-Inverted Data Output	
26	GND	Transmitter Ground (Common with Receiver Ground)	1
27	ModPrsl	Module Present	
28	IntL	Interrupt	2
29	VccTx	3.3V power supply transmitter	
30	Vcc1	3.3V power supply	
31	LPMode	Low Power Mode	2
32	GND	Transmitter Ground (Common with Receiver Ground)	1
33	Tx3+	Transmitter Non-Inverted Data Input	

34	Tx3-	Transmitter Inverted Data Output	
35	GND	Transmitter Ground (Common with Receiver Ground)	1
36	Tx1+	Transmitter Non-Inverted Data Input	
37	Tx1-	Transmitter Inverted Data Output	
38	GND	Transmitter Ground (Common with Receiver Ground)	1

Notes:

1. The module signal grounds are isolated from the module case.
2. This is an open collector/drain output that on the host board requires a 4.7KΩ to 10KΩ pull-up resistor to VccHost.

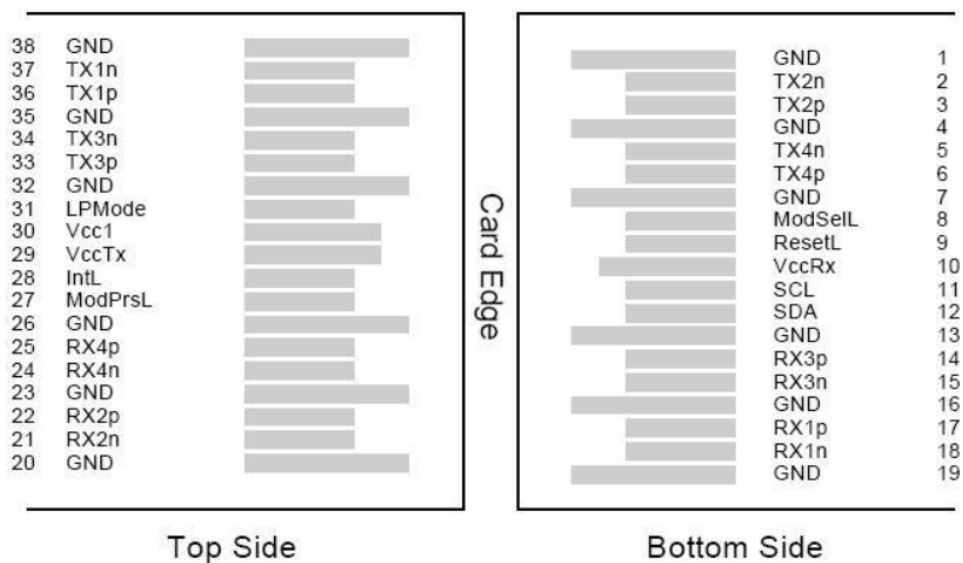

Figure 1. Host PCB QSFP+ pad assignment top view

Absolute Maximum Ratings

Stresses in excess of the absolute maximum ratings can cause permanent damage to the device. These are absolute stress ratings only. Functional operation of the device is not implied at these or any other conditions in excess of those given in the operational sections of the data sheet. Exposure to absolute maximum ratings for extended periods can adversely affect device reliability.

Table 3. Absolute Maximum Ratings

Parameter	Symbol	Minimum	Maximum	Unit
Storage Temperature	T _S	-40	85	°C
Relative Humidity	RH	5	85	%
Supply Voltage	V _{CC}	0	3.6	V

Recommended Operating Conditions

Table 4. Recommended Operating Conditions

Parameter	Symbol	Min	Typ	Max	Unit
Operating Case Temperature LX497x	T_C	0	25	70	°C
Supply Voltage	V_{CC}	3.135	3.3	3.465	V
Data Rate per Channel	-	-	4*10.3	-	Gb/s

Transceiver Electrical Characteristics

Table 5. Transceiver Electrical Characteristics

Parameter	Symbol	Minimum	Typical	Maximum	Unit	Notes
Supply Current	I_{CC}	-	-	400	mA	-
Power Dissipation	P_D	-	-	1500	mW	-
Clock Rate-I2C	f	-	-	400	kHz	3
Module Turn-on time	-	-	-	2000	ms	4

Notes:

1. For all control input pins: LPMode,Reset and ModSelL.
2. For all status output pins: ModPrsL,IntL.
3. For management interface.
4. Time from module power-on / insertion/ ResetL deassert to module full functional.

Transmitter Optical Characteristics

Table 6. Transmitter Optical Characteristics

Parameter	Symbol	Minimum	Typical	Maximum	Unit	Notes
Reference Differential Input Impedance	Z_d	-	100	-	Ω	1
Optical Return Loss Tolerance				12	dB	
Differential Data Input Swing	V_{in_pp}	180	-	1200	mV	-
Differential Data Input Threshold			50		mV	2

Notes:

1. AC coupled inside AOC module.
2. Input swing to trigger TX-squelch.

Receiver Optical Characteristics

Table 7. Receiver Optical Characteristics

Parameter	Symbol	Minimum	Typical	Maximum	Unit	Notes
Reference Differential Input Impedance	Z_d	-	100	-	Ω	1
Differential Data Output Swing	V_{out_pp}	0	-	800	mV	

	-	0	-	-	%	2
Pre-emphasis Pulse Amplitude Percentage	-	10	-	-	%	
	-	20	-	-	%	
	-	40	-	-	%	
Pre-emphasis Pulse Duration	-	-	30	-	ps	
Signal Speed	-	-	4*10.3	-	Gb/s	-
Differential Data Output Swing	-	150	-	850	mV	-
Differential Data Output Swing When Squelched	-	-	-	50	mV	-
Rise / Fall Time (20% ~80%)	-	24	-	-	ps	-

Notes:

1. AC coupled inside AOC module.
2. User selectable. Percentage is the ratio of pre-emphasis amplitude to output swing. Users could change by writing to page 3 address 237, default value is "10"

Recommended Application Interface Circuit

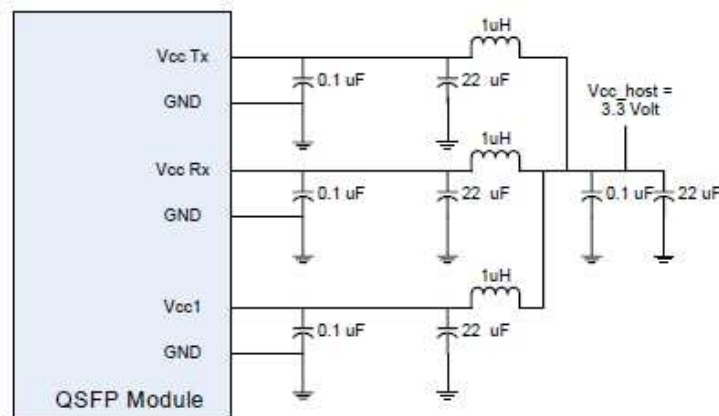
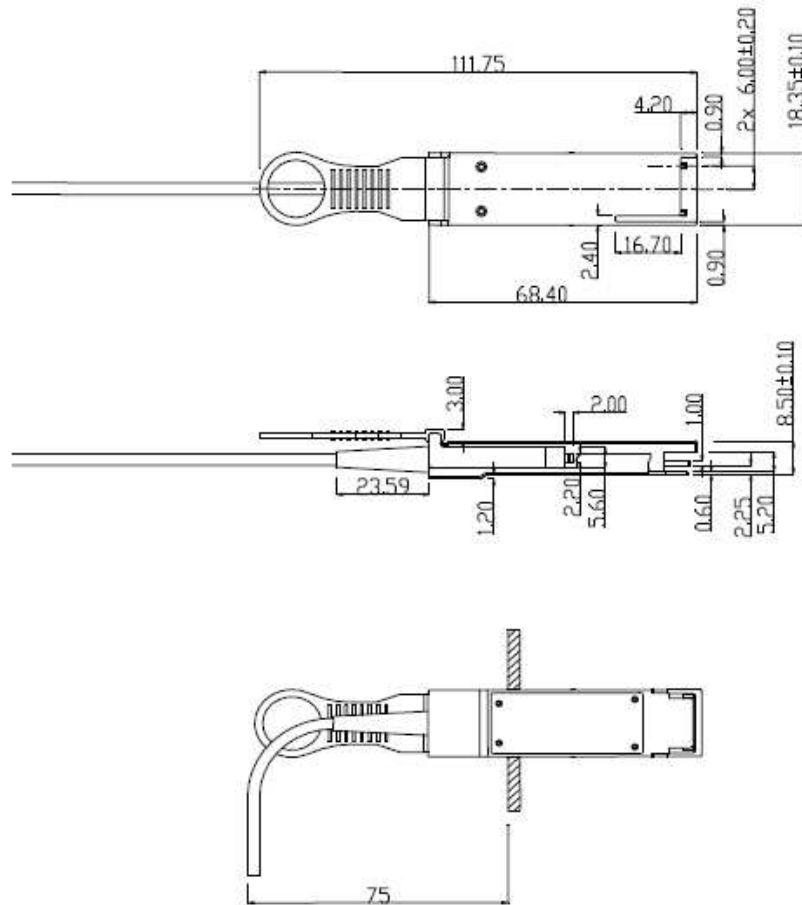

Figure 4. Recommended Host Board Power Supply Filter Network

Mechanical specifications

Parameter	Symbol	Minimum	Typical	Maximum	Unit	Notes
AOC cable length (L <=5m)	L	L-0.06	L	L+0.06	M	-
AOC cable length (L > 5m)	L	L-(L*1.1%)	L	L+(L*1.1%)	M	-
Module Retention	-	90	-	170	N	-
Module Insertion	-	0	-	18	N	-
Module Extraction	-	0	-	25	N	-
Cable Pull Strength – Apply Load at 0°	-	44	-	-	N	-

Cable Pull Strength – Apply Load at 90°	-	33	-	-	N	-
Clearance Out of IO Bezel	-	75	-	-	nm	-
Cable Bending Radius	-	3	-	-	cm	-
Insertion / Removal Cycles	-	50	-	-	cycles	-



Clearance 75mm Is Required.

Cable Type: Low Smoke Zero Halogen

Figure 5. Outline Drawing

For More Information

Linktel Technologies Co., Ltd

sales@linkteltech.com

<http://www.linkteltech.com>

Linktel China

E12, No.52 Liufang Road, East-Lake Hi-tech Development Zone, Wuhan, China

Tel: +86 27 8792 9298

Linktel USA

1601 McCarthy Blvd #9, Milpitas, CA 95035, USA

linktelus@linkteltech.com

Tel: +1 408 807 0482